

MODEL 36KW 3 PHASE 110 CONTROL CIRCUIT

Tankless, Inc.

Quality, Energy Saving, Tankless Hot Water Heaters

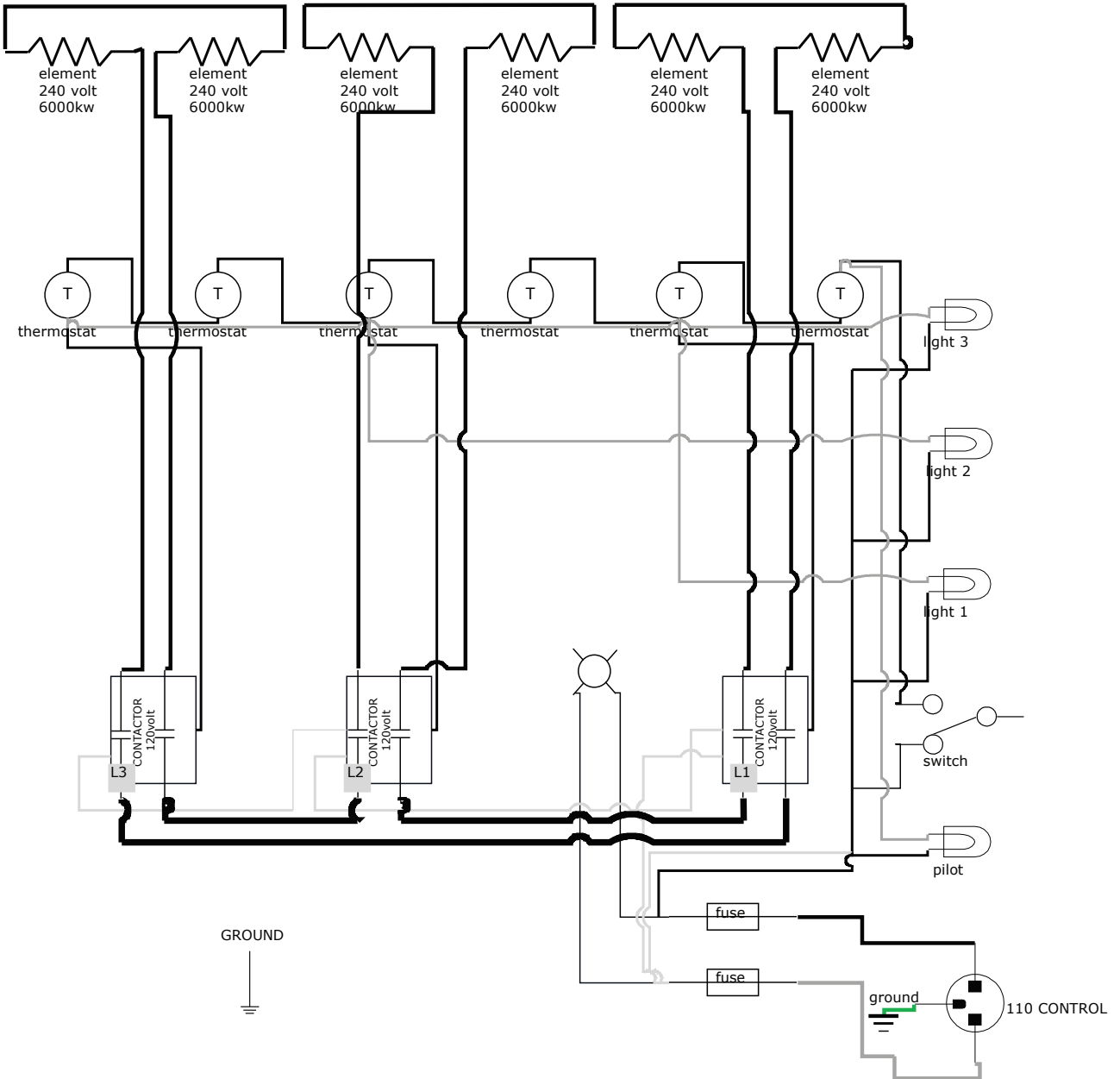

WIRE #16AWG

WIRE #10AWG

WIRE #8AWG

SINGLE LUG-AL DUAL RATED #2T

**NOTE: 36 KW 480 VOLT 3 PHASE 110 CONTROL CIRCUIT
USE 60 AMP BREAKER AND #6 THHN WIRE W/GROUND**



MODEL 36-6 KW 208 VOLT 3 PHASE

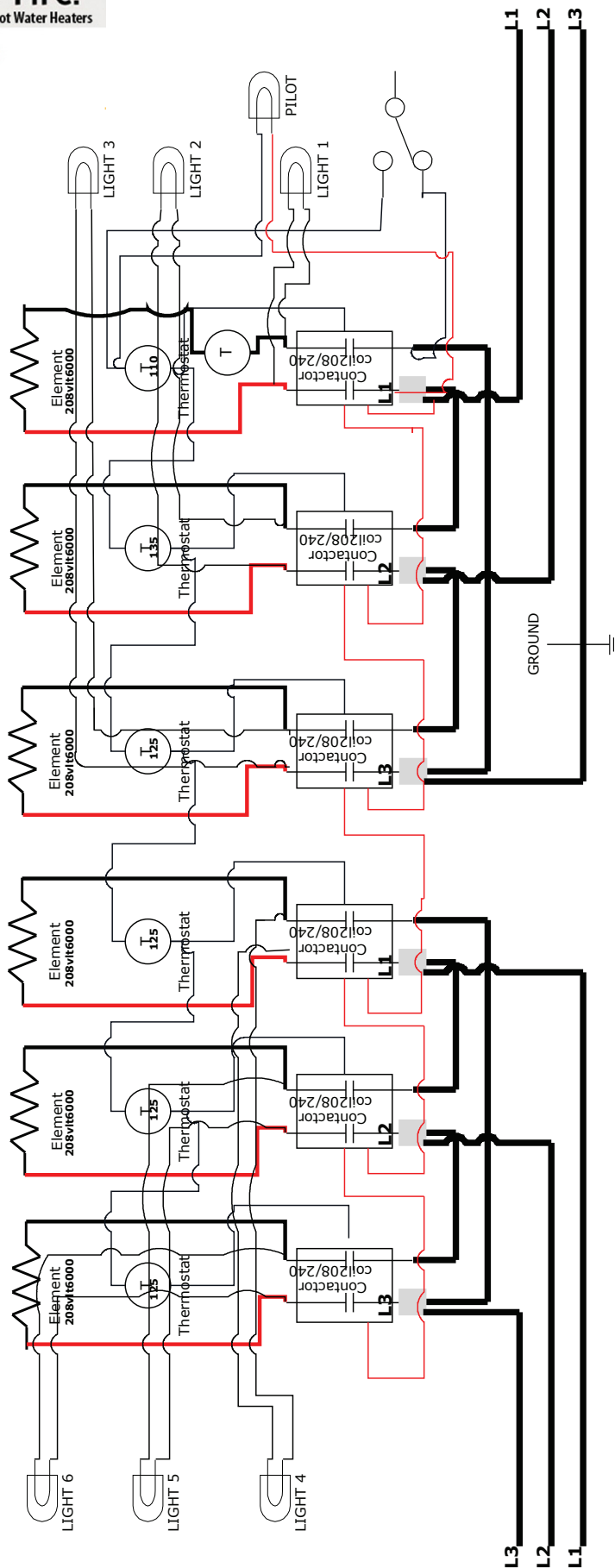

- WIRE #16AWG
- WIRE #10AWG
- WIRE #6AWG

MODEL 36KW 3 PHASE 110 CONTROL RECIRCULATION

Tankless, Inc.
Quality, Energy Saving, Tankless Hot Water Heaters

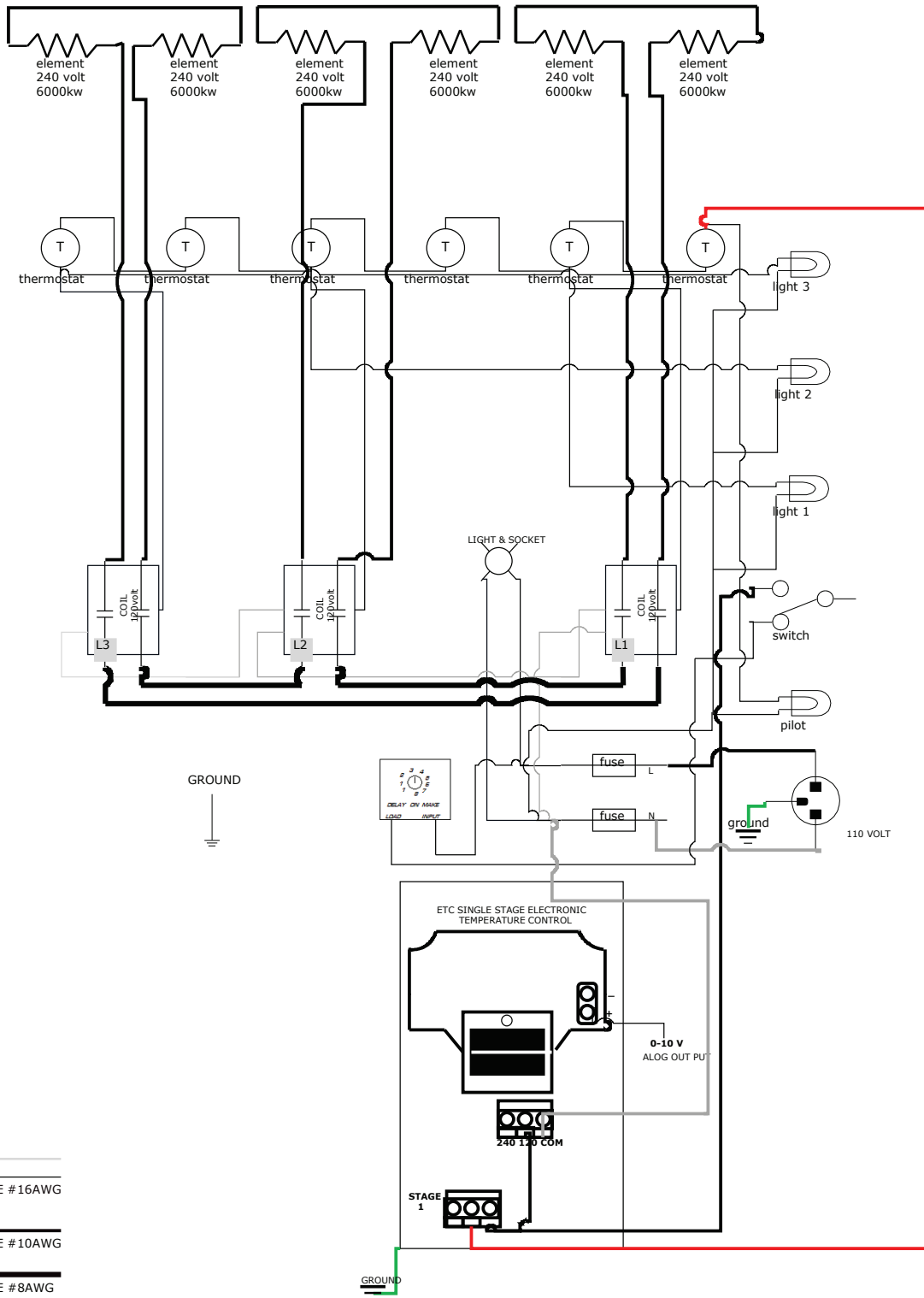

- WIRE #16AWG
- WIRE #10AWG
- WIRE #8AWG

SINGLE LUG-AL DUAL RATED #2T

**NOTE: 36 KW 480 VOLT 3 PHASE 110 CONTROL CIRCUIT RECIRCULATION
USE 60 AMP BREAKER AND #6 THHN WIRE W/GROUND**